



# 2010 East TN Regional Model Bridge Building Contest



**Objective:** To build a model bridge, according to prescribed size and weight specifications, that is capable of supporting the greatest load per unit of mass.

**Location:** American Museum of Science & Energy  
300 South Tulane Avenue, Oak Ridge, TN 37830 Fax (865) 576-6024  
AMSE Contact – Corwin Witt (865-576-3207) [cwitt@pstcc.edu](mailto:cwitt@pstcc.edu)

**Eligibility:** Students in grades 7-12

<b>Schedule:</b>	February 12, 2010 -	Send pre-registration forms to AMSE
	<b>February 20, 2010 -</b>	<b>Contest Date</b>
	8:30 a.m.-11:00 a.m. -	Registration
	10:00 a.m. -	Aesthetics judging
	11:00 a.m. -	Testing begins
	12:00 p.m. -2:00 p.m. -	Testing continues followed by award presentations
	March 6, 2010-	Snow Date

**Construction:** In accordance with the attached Model Bridge Building Specifications

**Sponsors:** American Museum of Science & Energy, American Society of Civil Engineers, Tennessee Society of Professional Engineers, and American Society of Mechanical Engineers

**Prizes:** Prizes will be awarded in each division for first, second, and third place for the bridges with the highest structural efficiency ( $E = \text{maximum load/model mass}$ )

**Senior High Division (grades 9\*-12)**

1<sup>st</sup> place – Trophy & \$150.00  
2<sup>nd</sup> place – Trophy & \$100.00  
3<sup>rd</sup> place – Trophy & \$50.00

**Junior High Division (grades 7-9\*)**

1<sup>st</sup> Place – Trophy  
2<sup>nd</sup> Place – Trophy  
3<sup>rd</sup> Place – Trophy

**Most Aesthetic Bridge will receive a trophy\*\***

**Bridge Contest Rules:**

1. The contest is open to high school and junior high school students grades 7-12.
2. Bridges must meet all specifications of the Model Bridge Building Contest. Those bridges not meeting specifications may be tested, but results will not count.
3. **\*\*A bridge must also meet specifications to qualify for the Aesthetics award. Bridges in Aesthetic category should be registered before 10:00 a.m. competition day or submitted by 5:00 p.m. Friday evening (February 19, 2010) to the AMSE by mail to be pre-judged.**
4. Bridges may be entered in person on the day of the contest. All bridges must be entered between 8:30 a.m. and 11:00 a.m.
5. Models will be tested in the museum auditorium on the contest day. Students and parents are encouraged to attend.
6. Bridges not claimed in one week will become property of the museum and will be used for display.
7. Judges will be provided by the contest sponsors. All decisions of the judges will be final.
8. Please check with website periodically for any corrections to rules and regulations and frequently asked questions. [www.amse.org](http://www.amse.org)
9. \*Ninth grade students may compete in either division; however, cash prizes are awarded only in the senior high division.

# 2010 East TN Regional Model Bridge Building Contest Bridge Specifications

---

## 1. Materials

- a.) The bridge must be constructed only from 3/32-inch square cross-section basswood and any commonly available adhesive.
- b.) The basswood may be notched, cut, sanded or laminated in any manner but must still be identifiable as the original basswood.
- c.) No other materials may be used. The bridge may not be stained, painted or coated in any fashion with any foreign substance.

## 2. Construction

- a.) The bridge mass shall be no greater than 30.0 grams.
- b.) The bridge (see Figure 1) must span a gap (**S**) of 300. mm, be no longer (**L**) than 400. mm, have a width (**W**) between 40. mm and 70. mm, and be no taller (**H**) than 180. mm above the support surfaces. It must have a horizontal loading plane that is a maximum height (**P**) of 80. mm above the support surfaces.
- c.) No portion of the bridge structure shall project below the support surfaces.
- d.) The bridge must be constructed to provide a horizontal support surface for the loading plate and rod at each of the three possible loading positions. These three positions, at the mid-span of the bridge and 60. mm to either side of the center, will be clearly and consecutively labeled "**1**, **2**, **3**" from either end of the bridge by the participant before submission to the judges (see 3b). The horizontal loading plane must be a minimum length (**R**) of 160. mm and be centered on the mid-span of the bridge. The bridge structure must allow the loading rod (see 3a) to be mounted to the loading plate from above the bridge, and must also allow the rod to cleanly pass through the bridge at the three loading points.
- e.) The bridge must have a minimum clearance (**C**) of 60. mm in height above the support surfaces. This clearance shall also extend 80. mm toward either end of the bridge from the center point of the bridge. It coincides with the horizontal loading plane, and lies directly beneath it. No part of the bridge structure may be built around this clearance area, and a 60. mm high, by 160. mm wide block must pass cleanly under the bridge.

## 3. Loading

- a.) The load will be applied downward, from above, by means of a 40. mm square loading plate that is 6.35 mm thick. A 9.52 mm (3/8") diameter loading rod is attached from above to the center of the plate (see Figure 2). The plate will be horizontal, it will not pivot on the loading rod, and the sides of the plate shall be placed parallel to the longitudinal axis of the bridge at the start of the loading.
- b.) The three loading positions will be located on the horizontal loading plane. The center loading position (numbered "**2**") will be located at the center point of the bridge. The other two loading positions (numbered "**1**" and "**3**") will be located 60. mm toward either end of the bridge from the center.
- c.) The same loading position will be used for all bridges tested.

## 2010 East TN Regional Model Bridge Building Contest Bridge Specifications

---

### 4. Testing

- a.) On the day of the contest the judges will select the loading location to be used. The bridges will be mounted into the test fixture such that loading point “1” faces stage right. The same location will be used for all the bridges tested.
- b.) The bridge will be centered on the support surfaces.
- c.) The loading plate will be located on the bridge and the load will be steadily applied from above to the bridge at the specified loading location. Competition loading will stop at 50. kg. However, loading will continue until failure of the bridge occurs.
- d.) Bridge failure is defined as the inability of the bridge to carry additional load, or a load deflection of 15. mm under the loading location, whichever occurs first.
- e.) The bridge with the highest structural efficiency,  $E$ , will be declared the winner, where  $E$  is defined as follows:

$$E = \text{Load supported in grams (50,000 g max.)} / \text{Mass of bridge in grams}$$

### 5. Qualification

- a.) All construction and material requirements will be checked prior to testing by the judges. Bridges that fail to meet these specifications at the conclusion of the allowable time for checking will be disqualified. Bridges disqualified prior to the start of the contest may be tested as exhibition bridges at the discretion of the builder and the contest directors.
- b.) If, during testing, a condition becomes apparent (i.e., use of ineligible materials, inability to support the loading plate, bridge optimized for a single loading point, etc.) which is a violation of the rules or prevents testing as described above in Section 4, that bridge shall be disqualified. If the disqualified bridge can accommodate loading, it may still be tested as an exhibition bridge as stated above.
- c.) Decisions of the judges are final; these rules may be revised as experience shows the need. (Please check The American Museum of Science & Energy Bridge Contest website at [www.amse.org](http://www.amse.org), after January 15, 2010, to learn whether any rule changes or clarifications have been made.)

**FIGURE 1: Bridge Schematic (not to scale)**

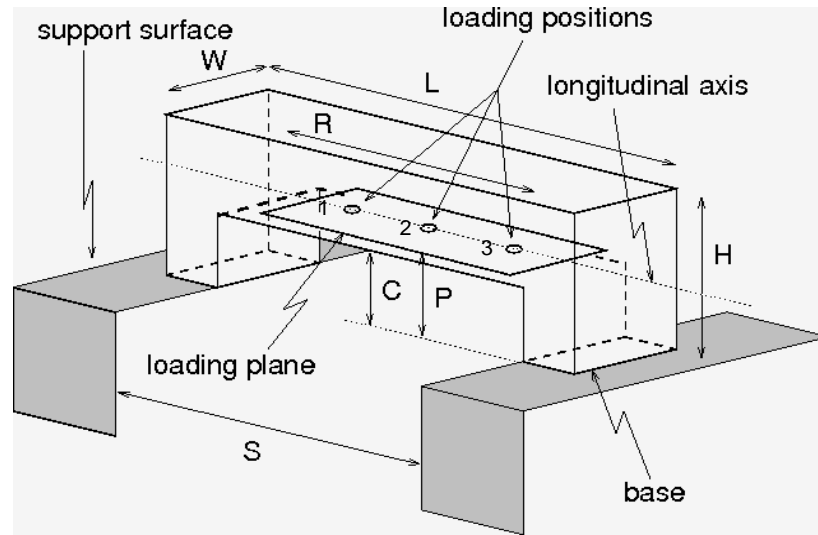

L = 400 mm Maximum

S = 300 mm span

D = loading plane must be a distance of 80 mm left and right of the center point of bridge

P = loading plane 80 mm Maximum height above support surface

R = Horizontal loading plane must be a minimum length of 160 mm and be centered on the mid-span of the bridge

H = 180 mm Maximum above support surface

W = Between 40mm and 70 mm

1, 3 = 60 mm toward either end of the bridge from the center

2 = center point of bridge

C = Minimum clearance of 60 mm above support surface and extends 80 mm toward either end of the bridge from the center point of the bridge.

**FIGURE 2: Loading Plate & Rod (not to scale) Load applied downward (from above)**

